

PRODUCT INFORMATION PACKET

Model No: 048T34D11002

Catalog No: K115A

0.50 HP General Purpose Motor, 3 phase, 3600 RPM, 230/460 V, 48 Frame, ODP
Three Phase ODP Motors



Regal and Marathon are trademarks of Regal Beloit Corporation or one of its affiliated companies.

©2020 Regal Beloit Corporation, All Rights Reserved. MC017097E

REGAL

Nameplate Specifications

Output HP	0.50 Hp	Output KW	0.37 kW
Frequency	60 Hz	Voltage	230/460 V
Current	1.8/0.90 A	Speed	3450 rpm
Service Factor	1.25	Phase	3
Efficiency	77 %	Power Factor	73.4
Duty	Continuous	Insulation Class	B
Design Code	NO DESIGN CODE	KVA Code	N
Frame	48	Enclosure	Drip Proof
Thermal Protection	No	Ambient Temperature	40 °C
Drive End Bearing Size	6205	Opp Drive End Bearing Size	6203
UL	Recognized	CSA	Y
CE	Y	IP Code	22

Technical Specifications

Electrical Type	Squirrel Cage Induction Run	Starting Method	Across The Line
Poles	2	Rotation	Reversible
Mounting	Rigid Base	Motor Orientation	Horizontal
Drive End Bearing	Ball	Opp Drive End Bearing	Ball
Frame Material	Rolled Steel	Shaft Type	NEMA 48
Overall Length	10.43 in	Frame Length	8.25 in
Shaft Diameter	0.500 in	Shaft Extension	1.5 in
Assembly/Box Mounting	F1 OUT ODE BRKT RADIAL		
Outline Drawing	048T34D11002-S01	Connection Drawing	D0000283-001

This is an uncontrolled document once printed or downloaded and is subject to change without notice. Date Created:14/12/2020

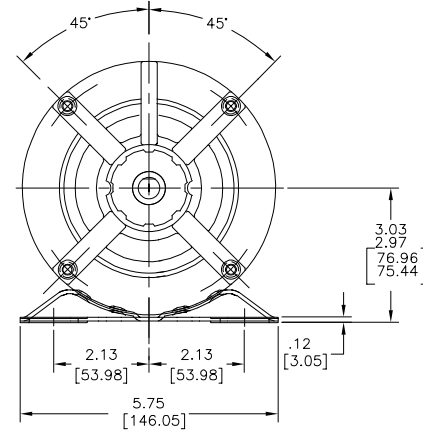
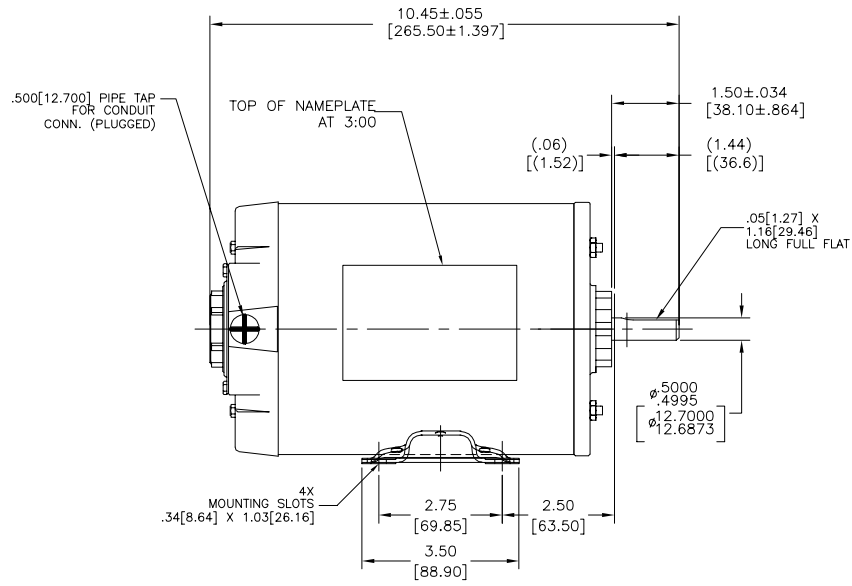

DRAWING REVISION A	REVISION BY J.ZHU	DATE 04-21-2015	TOLERANCES UNLESS OTHERWISE SPECIFIED DEC INCH mm ANGLE X ±0.1 [±2.5] ±0.5° XX ±0.02 [±0.51] XXX ±0.005 [±0.127] XXXX ±0.0005 [±0.0127]	DRAWN BY: J.ZHU	 Regal Beloit America, Inc.
ECC-0076224	APPROVED BY J.ZHU	DATE 04-21-2015	REMOVE BURRS & BREAK SHARP EDGES .003/.015 [0.076/.381] CORNER FILLETS .02 [1.51] MACHINED SURFACES .125/32 mm SHOWN IN BRACKETS	DATE: 04-21-2015	
ECC DESCRIPTION NEW MODEL RELEASE			REFERENCE	APPROVED BY: J.ZHU	DESCRIPTION MODEL-CFHP-48FR OUTLINE
<small> COPYRIGHT REGAL BELOIT AMERICA, INC. ALL RIGHTS RESERVED. PROPRIETARY AND CONFIDENTIAL INFORMATION - THIS DOCUMENT IS THE PROPERTY OF REGAL BELOIT AMERICA, INC. IT IS NOT TO BE REPRODUCED OR TRANSMITTED IN ANY FORM OR BY ANY MEANS, ELECTRONIC OR MECHANICAL, INCLUDING PHOTOCOPYING, RECORDING, OR BY ANY INFORMATION STORAGE AND RETRIEVAL SYSTEM, WITHOUT THE WRITTEN PERMISSION OF REGAL BELOIT AMERICA, INC. ANY UNAUTHORIZED REPRODUCTION OR DISTRIBUTION OF THIS DOCUMENT IS PROHIBITED. REGAL BELOIT AMERICA, INC. IS NOT RESPONSIBLE FOR ANY DAMAGE TO PERSONS OR PROPERTY, OR FOR ANY LOSS OF PROFITS, BUSINESS, OR REPUTATION, OR FOR ANY SPECIAL, INCIDENTAL, OR CONSEQUENTIAL DAMAGES, INCLUDING ATTORNEY'S FEES, ARISING FROM THE USE OF THIS DOCUMENT, EVEN IF SUCH DAMAGE IS CAUSED BY THE NEGLIGENCE OF REGAL BELOIT AMERICA, INC. </small>			MATERIAL	DATE: 04-21-2015	PROCESS/FINISH
			THIRD ANGLE PROJECTION	REFERENCE	SIZE (DWG NO)
					048T34D11002
					SHEET 1

4

3

2

1

REV	ECO	REV BY	DATE	APPD	DATE
A	0016784	R.RASCON	10-12-2010	D.JUAREZ	10-12-2010

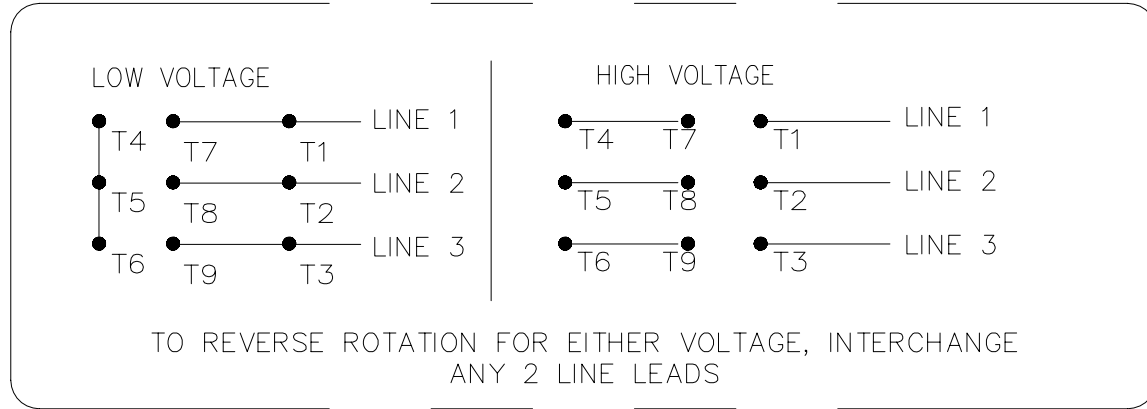

NOTES:

1. DATTED BOX REPRESENTS TOTAL PRINTED AREA ALLOWED FOR CONNECTION DIAGRAM TO FIT IN (.75[19.1] X 2.13[54.1]) SEE NAMEPLATE DRAWING 170500 OR 170501 FOR LOCATION.
2. CHARACTERS ARE TO BE A MINIMUM OF .03[.8] TO .06[1.5] MAXIMUM IN HEIGHT.
3. DETAILS ARE NOT TO BE COPIED FROM DRAWING, BUT ARE TO BE REPRODUCED FROM ORIGINAL ARTWORK FURNISHED.

GEOMETRIC CHARACTERISTICS & SYMBOLS

- ▭ FLATNESS
- STRAIGHTNESS
- ∠ ANGULARITY
- ⊥ PERPENDICULARITY (SQUARENESS)
- // PARALLELISM
- ROUNDNESS (CIRCULARITY)
- ⊘ CYLINDRICITY
- △ PROFILE OF ANY SURFACE
- ⌒ PROFILE OF ANY LINE
- ↗ RUNOUT
- ⊕ TRUE POSITION
- ⊙ CONCENTRICITY
- ≡ SYMMETRY

UNLESS OTHERWISE SPECIFIED
 DIM. TOLERANCES ARE AS FOLLOWS:
 INCH X XX XXX XXXX
 mm ±0.1 ±0.02 ±0.005 ±0.0005
 mm ±0.5 ±0.13 ±0.013
 ANG. ±.50 DEG
 REMOVE BURRS & BREAK SHARP EDGES:
 INCH .003-.015 mm 0.1-0.4
 CORNER FILLETS TO:
 INCH .020 mm 0.5
 MACHINE SURFACES:
 INCH 125 mm 3.2
 METRIC DIMS. SHOWN IN [BRACKETS]

DR BY:	R.RASCON	10-12-2010
APPD:	D.JUAREZ	10-12-2010
THIRD ANGLE PROJECTION		EDS DATE 02-22-2008 FORMAT REV F
CONFIDENTIAL: THIS DRAWING AND ITS INFORMATION ARE THE EXCLUSIVE AND CONFIDENTIAL PROPERTY OF A.O. SMITH CORP. AND ARE NOT TO BE DISCLOSED, DUPLICATED, DISTRIBUTED OR OTHERWISE USED WITHOUT THE WRITTEN CONSENT OF A.O. SMITH CORP. -ALL RIGHTS RESERVED. ASME Y14.5M 1994		

ELECTRICAL PRODUCTS COMPANY <small>A DIVISION OF A. O. SMITH CORPORATION</small>	
DESCRIPTION CONN DIAGRAM-NAMEPLATE	
SIZE B	DWG NO D0000283-001
SCALE NONE	SHEET 1

4

3

2

1

4

3

2

1

REVISION:	ECO	REVISADO POR:	FECHA:	APROBADO POR:	FECHA:
A	0016784	R.RASCON	10-12-2010	D.JUAREZ	10-12-2010

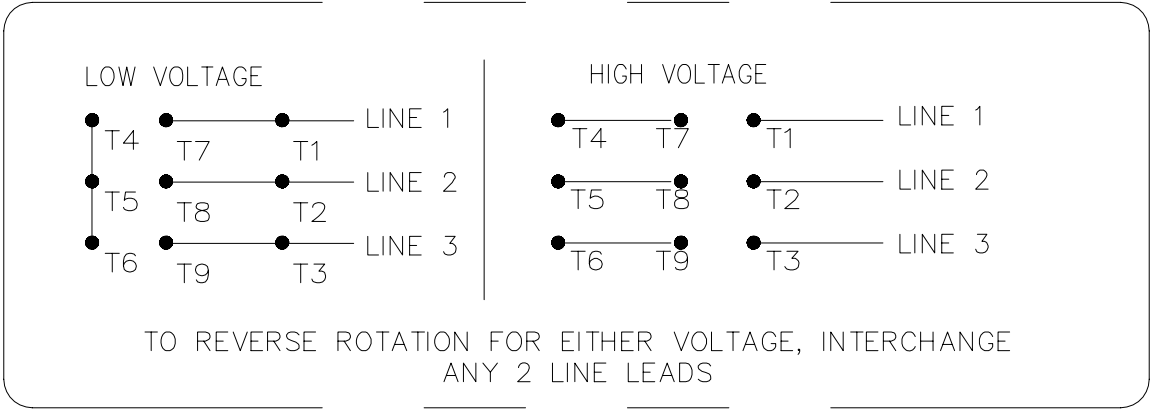

- NOTAS:
1. LA CAJA PUNTEADA REPRESENTA EL TOTAL DEL AREA IMPRESA TOTAL PERMITIDA PARA UN DIAGRAMA DE CONEXION PA5A ANCAJAR EN (.75[19.1] X 2.13 [54.1]) VER EL DIBUJO DE LA PLACA DE IDENTIFICACION 170500 O 170501 PARA LOCALIZACION.
 2. LOS CARACTERES DEBEN SER DE UN MINIMO DE ALTURA DE .03[.8] A UN MAXIMO DE .06[1.5].
 3. LOS DETALLES NO DEBEN SER COPIADOS DEL DIBUJO, SINO DEBEN SER REPRODUCIDOS DE LAS ILUSTRACIONES ORIGINALES EQUIPADAS.

A

A

CARACTERISTICAS DE GEOMETRIA Y SIMBOLOS ▽ PLANICIDAD — RECTITUD ∠ ANGULARIDAD ⊥ PERPENDICULARIDAD (A ESCUADRA) // PARALELISMO ○ REDONDEZ (CIRCULARIDAD) ∅ CILINDRICIDAD ⊖ PERFIL DE CUALQUIER SUPERFICIE ⊖ PERFIL DE CUALQUIER LINEA ↗ VARIACION ⊕ POSICION REAL ⊙ CONCENTRICIDAD = SIMETRIA	A MENOS QUE SE ESPECIFIQUE DE OTRA MANERA, LAS TOLERANCIAS DE LAS DIMS; SON LAS SIGUIENTES: PULG ±.1 ±.02 ±.005 ±.0005 mm ±0.5 ±0.13 ±0.013 ANG. ±50 GRADOS ELIMINAR REBABAS Y ORILLAS FILOSAS DEL BORDE. PULG .003-.015 mm 0.1-0.4 FILETEAR ESQUINA: PULG .020 mm 0.5 MAQUINAR SUPERFICIES PULG 1/25 mm 3/2	DIBUJADO POR: R.RASCON 10-12-2010	ELECTRICAL PRODUCTS COMPANY A DIVISION OF A. O. SMITH CORPORATION
	APROBADO POR: D.JUAREZ 10-12-2010	DESCRIPCION: CONN DIAGRAM-NAMEPLATE	
	TERCER ANGULO DE PROYECCION 	FECHA EDS: 02-22-2008 REV. FORMATO: F	TAMAÑO: B NUMERO DE DIBUJO: D0000283-001
	CONFIDENCIAL: ESTE DIBUJO Y SU INFORMACION SON PROPIEDAD DE USO EXCLUSIVO Y CONFIDENCIAL DE A.O.SMITH CORP. Y NO DEBERAN SER REVELADOS, DUPLICADOS, DISTRIBUIDOS O USARSE DE OTRA MANERA SIN EL CONSENTIMIENTO ESCRITO DE A.O. SMITH CORP. -TODOS LOS DERECHOS RESERVADOS.ASME Y14.5M 1994	ESCALA: NONE HOJA: 1	

4

3

2

1

4

3

2

1

版本	ECO	编制	日期	批准	日期
A	0016784	R.RASCON	10-12-2010	D.JUAREZ	10-12-2010

LOW VOLTAGE

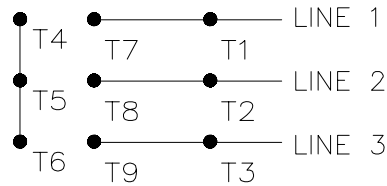

HIGH VOLTAGE

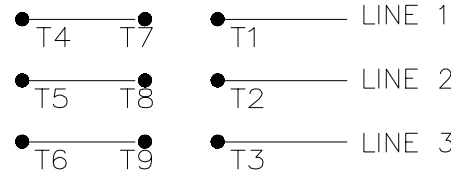

TO REVERSE ROTATION FOR EITHER VOLTAGE, INTERCHANGE ANY 2 LINE LEADS

- 形位公差
- 平面度
- 直线度
- ∠ 倾斜度
- ⊥ 垂直度
- // 平行度
- 圆度
- ⊘ 圆柱度
- ⌒ 面轮廓度
- ⌒ 线轮廓度
- ↗ 圆跳动
- ⊕ 位置度
- ◎ 同轴度
- ≡ 对称度

除另有注明
尺寸公差如下:
 英寸 X XX XXX XXXX
 毫米 ±.1 ±.02 ±.005 ±.0005
 英寸 ±.1 ±.02 ±.005 ±.0005
 毫米 ±0.5 ±0.13 ±0.013
 角度 ±.50 度
 清理毛刺和尖棱
 英寸 .003-.015 毫米 0.1-0.4
 内圆角
 英寸 .020 毫米 0.5
 表面粗糙度
 英制 125 米制 3.2
 米制尺寸显示在 []

绘图:	R.RASCON	10-12-2010
批准:	D.JUAREZ	10-12-2010
第三角投影		图纸格式发布日期 02-22-2008 图纸格式版本 F
机密: 本图纸及相关信息所有权归A. O. SMITH公司所有。 未经A. O. SMITH公司书面授权, 不得泄露、复制、传播或作其他用途。--版权所有		
ASME Y14.5M 1994		



ELECTRICAL PRODUCTS COMPANY
A DIVISION OF A. O. SMITH CORPORATION

名称		CONN DIAGRAM-NAMEPLATE	
图幅	B	图号	D0000283-001
比例	NONE	页号	1

4

3

2

1